

DATASENSING
easing automation challenges

LGS A10 Compact Lidar

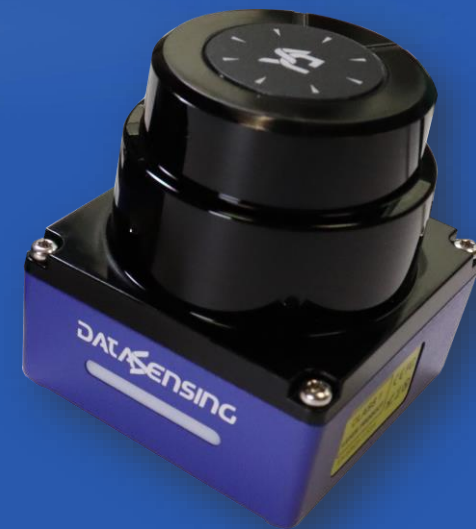

Enrico Lorenzoni

**OUR EXPERTISE
MAKES YOUR WORK
EASIER**



LGS-A10 at a glance

LGS-A10 : 360° lidar for collision detection and object detection

958200003

+



LGS Pro User Interface for detection areas drawing and device setting

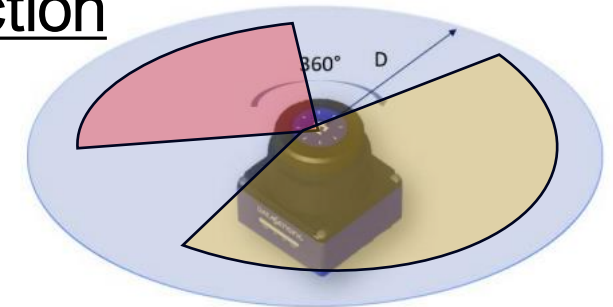
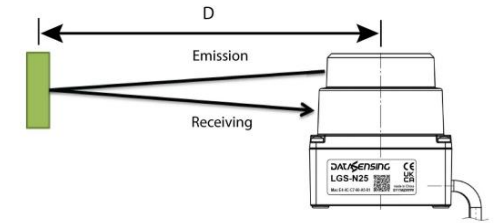

The LGS-A10 is a rugged and compact lidar with excellent performances suitable for vehicles collision avoidance, object detection in programmable monitored areas for industrial-grade applications.

Particularly suitable in intralogistics for small automated mobile robots (AMR), automated guided vehicle (AGV), forklift and carts , it can be used as well in automated manufacturing or logistic plants for access monitoring and shapes control .

Its design and characteristics allow a reliable detection also for the outdoor use, so it can be used as well in applications in fields as agriculture, transportation, earth moving machines and more.

LGS-A10 is easy to set by a dedicated user interface and has a quick commissioning; it adopts an UDP standard by an Ethernet connection to supplies measurement data, and have a suite of physical I/O to monitoring the detection and to change the zone sets of monitored areas

■ Main Performances

- INDOOR & OUTDOOR
 - IP67
 - Immunity to moderate intensity rain
 - High ambient light rejection (120Klux)
 - High operating temperature range (-10 .. 60°C)
- 65x65x70 mm
- 25Hz scan rate (with 1° angular resolution)
- 0,25° angular resolution (with 10Hz scan rate)
- 25m range@white 90% / 5m range@black 3.5%
- +/-30mm accuracy / 20mm Repeatability
- 360° Angular range
- 10m @ grey 10% range for detection
- 80 ms output response time (best)
- 3 simultaneous digital outputs
- 16 zone set available (by 4 input switch)

LGS

OUTDOOR



COMPACT SIZE



PERFORMANCES



PRICE



Performances and specs

GENERAL SPECIFICATIONS	
Wavelength	905 ± 20 nm
Laser class	Class 1
Channel	1
Scanning angle	360°
Scanning rate	10, 15, 25 Hz
Ambient light limit	>80000 LUX @ sunlight
Light spot divergence angle	8(H); 3(V) mrad
Horizontal plane error	<= 0,8°

INTERFACE	
Interface type	IEEE 802.3u 100Mbps Ethernet
Protocol	UDP TCP/IP

ELECTRICAL SPECIFICATIONS	
Operation voltage	9 to 30 VDC
Power consumption (25°C)	< 5W @15Hz
Input Max current	50 mA
Input Voltage Min for ON status	0 V
Input Voltage Max for OFF status	VDC-0.1 V
Input Impedance	6.8 KΩ
Input max switching frequency	4.5 / 6.5 / 10 Hz
Input protection	36 V
Output Max load current	50 mA
Output Voltage Min ON Status	0.7 V
Output Voltage Max OFF Status	VDC
Output Voltage Drop Max	30 V
Output Max Capacitive Load	1 uF
Output Max Capacitive Load	2.2 mH
Output Max Switching Frequency	8 / 11 / 16 Hz
Output Protection	85° C
Power connector	12pin, M12x1 Connector Standard
Communication Interface	4pin, M12x1 socket D-coded

MEASUREMENT PARAMETERS	
Absolute accuracy	<± 30 (0.4~10m)
Repeat accuracy	<= 20 (0.4~10m)
Angle resolution	0.25° @ 10 Hz / 0.5° @ 15 Hz / 1° @ 25 Hz
Working distance (based on reflectivity)	0.1~10m @ 80%
Resolution of output distance	1 mm
Point cloud density	14.4K@10Hz, 10.8K@15Hz, 9K@25Hz
Signal intensity	0-20000

AMBIENT CONDITIONS	
Operating temperature	-10 to +60 °C
Storage temperature	-20 to +70 °C
Relative humidity	< 95% (No Condensation)

MECHANICAL SPECIFICATIONS	
Housing width	65 mm
Housing length	65 mm
Housing height	70 mm
Degree of protection	IP67
Material	Body and cap: aluminum Window: polycarbonate Panel and LED cover: polycarbonate and ABS
Mass	< 500 g

COMPLIANCE AND CERTIFICATIONS	
Vibration	IEC 60068-2-6:2007
Shock	IEC 60068-2-27:2008
EMC	IEC 61000-6-2:2016-08 / IEC 61000-6-3:2006-07
Laser safety	IEC 60825-1
ROHS	✓
Safety requirements	UL61010-1

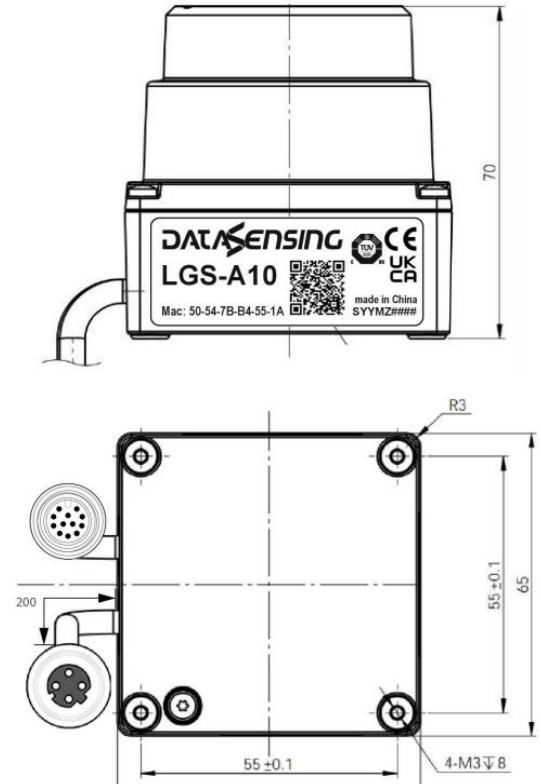

Connection

Ethernet

No.	DEFINITION
1	Transmit data +
2	Receive data +
3	Transmit data -
4	Receive data -

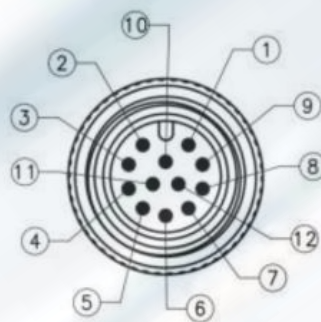
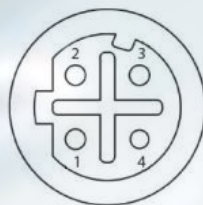

Power and I/O

PIN #	PIN NAME	PIN DESCRIPTION	CONNECTION DIAGRAM	NOTE ON I/O STATUS	WIRING COLOR
1	+VCC	POWER			Brown
2	GND	GROUND			Blue
3	INPUT 1	ZONE SET SWITCH INPUT 1		INPUT # = HIGH if floating or connected to VCC_I/O INPUT # = LOW if connected to GND_I/O	White
4	INPUT 2	ZONE SET SWITCH INPUT 2			Green
5	INPUT 3	ZONE SET SWITCH INPUT 3			Pink
6	INPUT 4	ZONE SET SWITCH INPUT 4			Yellow
7	GND I/O	GROUND for I/O			Black
8	OUT_1	DETECTION OUTPUT 1		No Target detection: Iload > 0 Target detection: Iload = 0	Grey
9	+VDC_I/O	POWER for I/O			Red
10	OUT_2	DETECTION OUTPUT 2		No Target detection: Iload > 0 Target detection: Iload = 0	Violet
11	OUT_3	DETECTION OUTPUT 3		No Target detection: Iload > 0 Target detection: Iload = 0	Grey/Pink
12	OUT_4	ERROR OUTPUT 4		No Error status: Iload > 0 Error status: Iload = 0	Red/Blue

Data transmission

The output of LGS is a cloud of data related to the points detected around the scanner
The transmission is done through Ethernet port 100Mbps, with UDP/IP protocol.

Data used for localization:

In the header:	Timestamp	[ms]
In each block:	Angle	[°]
	Distance	[mm]
	Signal strenght	[0..65535]



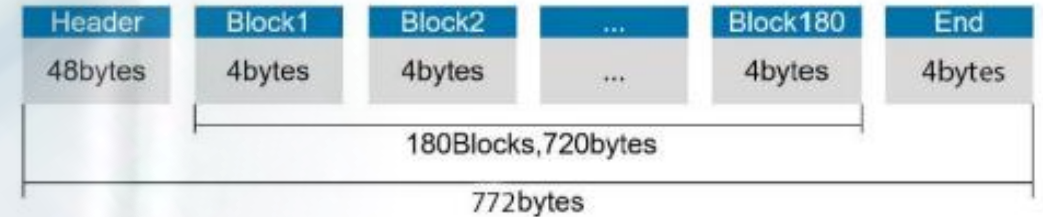





INTERFACE	
Interface type	IEEE 802.3u 100Mbps Ethernet
Protocol	UDP TCP/IP



The signal strength is proportional to the intensity of the beam received and can be used to distinguish the reflector from other surfaces.

The drive for ROS node is available in the [Datasensing website](#)

Product user interface

LED	MEANING
	Power On. Red and Green lights are always ON.
	Start. Device self checking, Red and Green LED flash.
	Normal operation. Red OFF, Green LED flash.
	Fault. Red ON, Green LED flash.
	OUT1 activation. Green ON, Red flash. TON1=0.4s; TOFF1=2s
	OUT2 activation. Green ON, Red flash. TON1=0.4s; TOFF1=0.4s; TON2=0.4s; TOFF2=2s
	OUT3 activation. Green ON, Red flash. TON1=0.4s; TOFF1=0.4s; TON2=0.4s; TOFF2=0.4s; TON3=0.4s; TOFF3=2s
	Multi Area. Green ON, Red flash. When any two areas are triggered simultaneously, the alarm status of the intercepted area with higher priority is displayed. Priority level: OUT 1 > OUT 2 > OUT 3

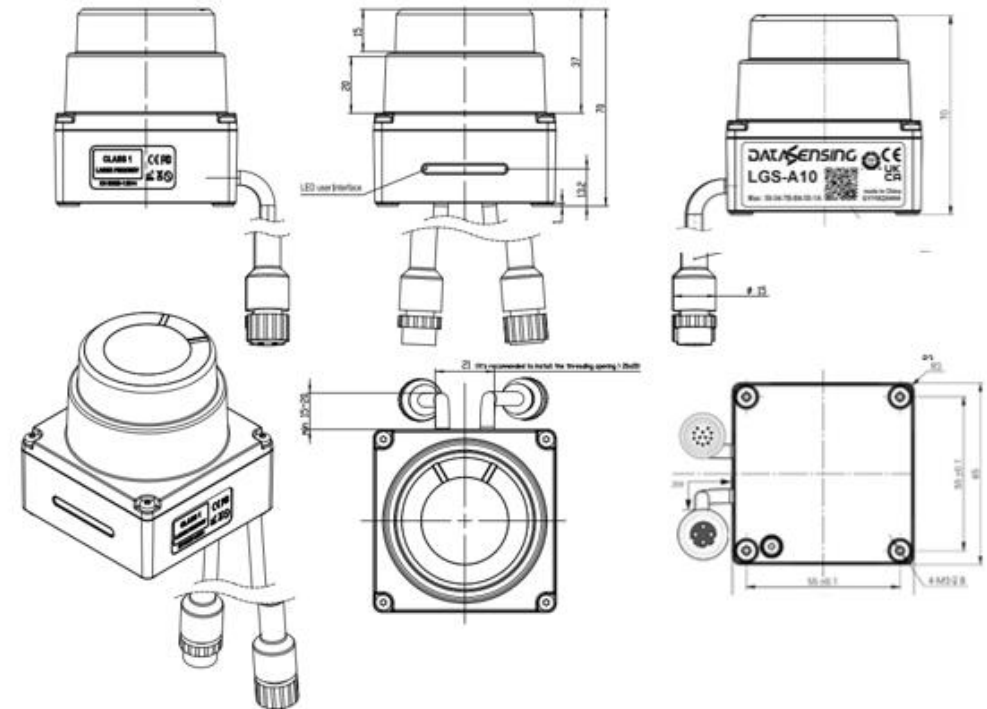

LGS-PRO user interface

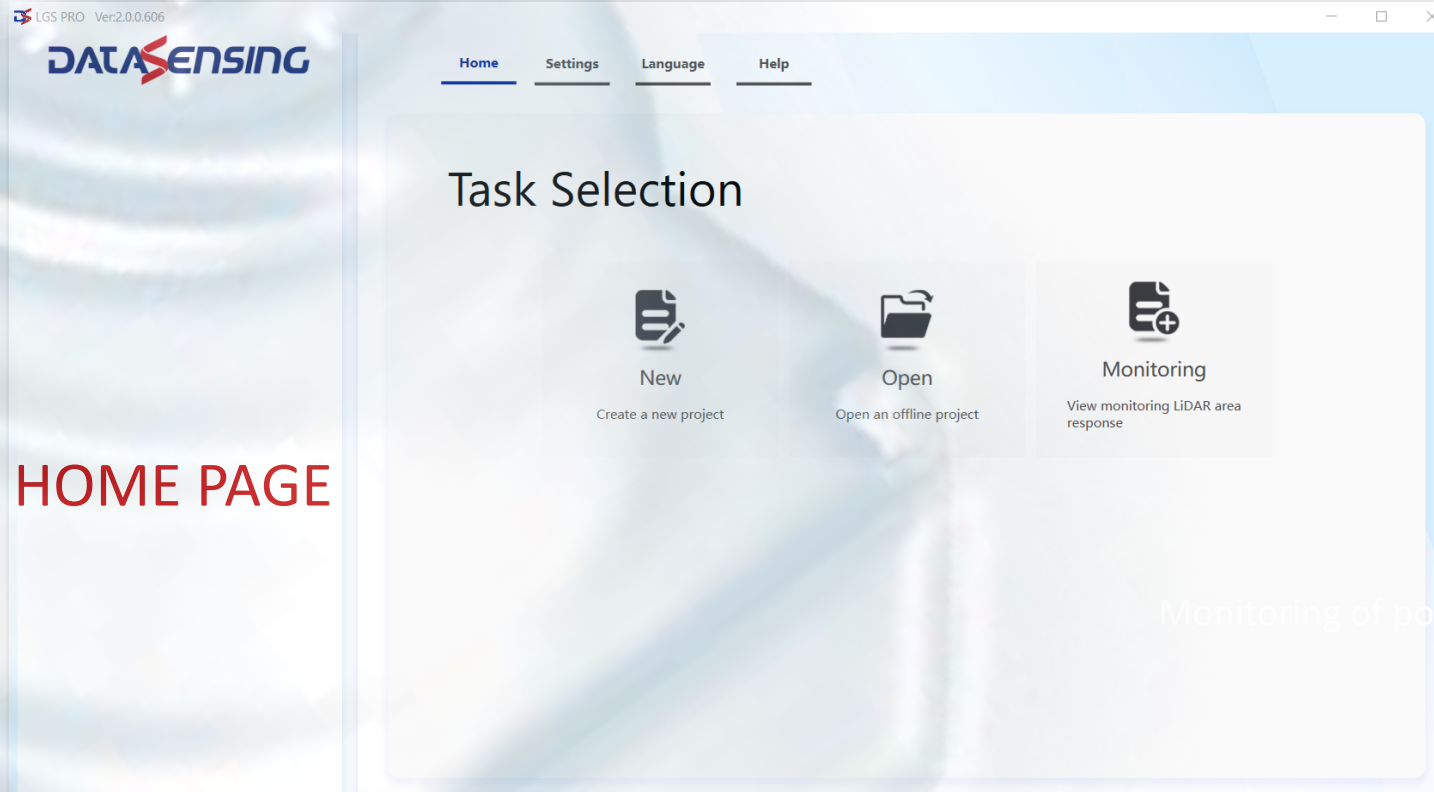

HOME PAGE

LGS-PRO

- It's a software for pc under Window operating system
- it's needed to configurate the LGS-A10 and for its data monitoring
- it's free of charge and available for download in Datasensing website



LGS-PRO user interface



A screenshot of the LGS-PRO user interface. The window title is 'LGS PRO Ver:2.0.0.606'. The interface has a navigation bar with 'Home', 'Settings', 'Language', and 'Help'. Below the navigation bar, there's a section for 'Select the connected LiDAR:' with tabs for 'Online in the network' and 'Supported LiDAR'. A 'Monitoring' section is visible on the left with a 'Find' button. The main content area displays 'LGS-A10' with an image of the device and a list of specifications: Model: LGS-A10, PartNo: --, SerialNo: --, Firmware Version: --, Host: --, and LiDAR IP: --. A 'NEXT' button with a right arrow is located on the right side of the main content area.

PRODUCT
DISCOVERY



LGS-PRO user interface

Drawing tools

Output selection for Area drawing

Zone set selection

CONFIGURATION PAGE

Manual input Area drawing

LGS PRO Ver:2.0.0.606

DATASENSING

LGS-A10
192.168.1.100
S/N:LGS-A10-202309-0001

New Open Save As

0 OUT 1 OUT 2 OUT 3

1 OUT 1 OUT 2 OUT 3

2 OUT 1 OUT 2 OUT 3

3 OUT 1 OUT 2 OUT 3

OUT 1

Zoneset[1]

Pt	X(m)	Y(m)
1	-4.351	1.202
2	-0.208	-3.866

XY Polar

Home Settings Language Help

Configuration Save to sensor

Angle: 178.29° Range: 3.372m

Zoneset[1]

3m 2.5m 2m 1.5m 1m 0.5m 0m -0.5m -1m -1.5m -2m -2.5m -3m -3.5m -4m

-6m -5m -4m -3m -2m -1m 0m 1m 2m 3m 4m 5m 6m 7m

Drawing tools: Eraser, Line, Polygon, Circle

LGS-PRO user interface

menu

Configuration save

LGS PRO Ver:2.0.0.606

DATA SENSING

LGS-A10
192.168.1.100
S/N:LGS-A10-202309-0001

Config. File →

CONFIGURATION PAGE

Setting →

Response time →

0	OUT 1	OUT 2	OUT 3	
1	OUT 1	OUT 2	OUT 3	
2	OUT 1	OUT 2	OUT 3	
3	OUT 1	OUT 2	OUT 3	
	OUT 1			

Zoneset[0]

Area | Data

Detection Capability: 3

Number of Scans (Ns): 1

Response Time: 200 ms

Restore Time: 400 ms

Home Settings Language Help

Configuration

Save to sensor

Angle: 306.01° Range: 7.479m

Zoneset[0]

Setting

Response time

LGS-PRO user interface

Lidar web page

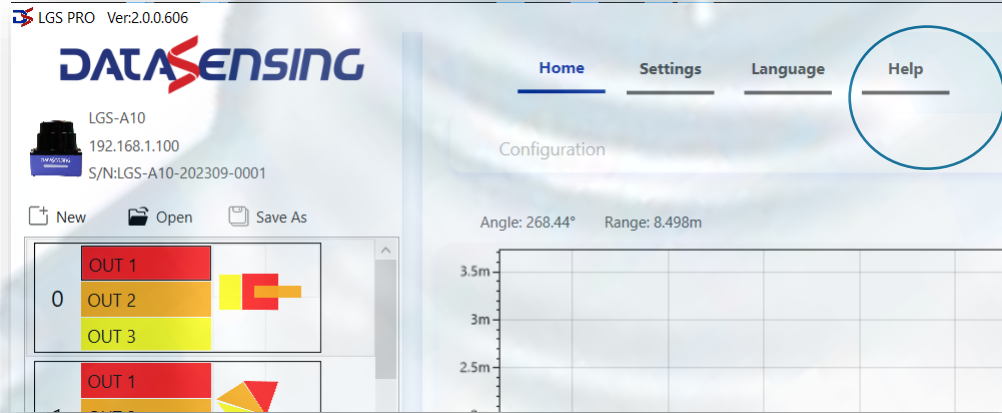

WEB SETTING PAGE

The screenshot shows the "Datasensing LiDAR Config" web page. At the top left is the "DATASENSING" logo. The page title is "Datasensing LiDAR Config". Below the title, it displays "Model: LGS-A10", "MAC: 50-54-7B-B4-53-8E", "HardVer: 0.4.0", and "SoftVer: 0.0.8". The page is divided into several sections:

- LiDAR Config:** Motor RPM: 600 (dropdown), Angle offset: 0 (input) (0.00~360.00°), Set Configs button.
- Temperature:** Main board: 52.9 °C, Recv board: 56.4 °C.
- Voltage:** CPU core: 3.30 V, Recv board: 167.17 V.
- Net Config:** Host IP & Port: 192.168.1.10 & 2368, DHCP: OFF (radio button), LiDAR IP: 192.168.1.100, Net Mask: 255.255.255.0, Gateway: 192.168.1.1, NTP: OFF (radio button), Set Networks button.
- Miscellaneous:** Motor speed: 599.9, Points/Circle: 1440, Zoneset: 3, Detection/Ns: 5_01.

At the bottom of the page is the "DATASENSING" logo.

LGS-PRO user interface

Selected Zone Set

ZONE SET #	INPUT 1	INPUT 2	INPUT 3	INPUT 4
0	GND_I/O	GND_I/O	GND_I/O	GND_I/O
1	GND_I/O	GND_I/O	GND_I/O	+VCC_I/O (OR floating)
2	GND_I/O	GND_I/O	+VCC_I/O (OR floating)	GND_I/O
3	GND_I/O	GND_I/O	+VCC_I/O (OR floating)	+VCC_I/O (OR floating)
4	GND_I/O	+VCC_I/O (OR floating)	GND_I/O	GND_I/O
5	GND_I/O	+VCC_I/O (OR floating)	GND_I/O	+VCC_I/O (OR floating)
6	GND_I/O	+VCC_I/O (OR floating)	+VCC_I/O (OR floating)	GND_I/O
7	GND_I/O	+VCC_I/O (OR floating)	+VCC_I/O (OR floating)	+VCC_I/O (OR floating)
8	+VCC_I/O (OR floating)	GND_I/O	GND_I/O	GND_I/O
9	+VCC_I/O (OR floating)	GND_I/O	GND_I/O	+VCC_I/O (OR floating)
10	+VCC_I/O (OR floating)	GND_I/O	+VCC_I/O (OR floating)	GND_I/O
11	+VCC_I/O (OR floating)	GND_I/O	+VCC_I/O (OR floating)	+VCC_I/O (OR floating)
12	+VCC_I/O (OR floating)	+VCC_I/O (OR floating)	GND_I/O	GND_I/O
13	+VCC_I/O (OR floating)	+VCC_I/O (OR floating)	GND_I/O	+VCC_I/O (OR floating)
14	+VCC_I/O (OR floating)	+VCC_I/O (OR floating)	+VCC_I/O (OR floating)	GND_I/O
15	+VCC_I/O (OR floating)	+VCC_I/O (OR floating)	+VCC_I/O (OR floating)	+VCC_I/O (OR floating)

LGS PRO Ver:2.0.0.606

DATASENSING

LGS-A10
192.168.1.100
S/N:LGS-A10-202309-0001

15	OUT 1		
	OUT 2		
	OUT 3		

RPM: 601
Points: 1440
Detection Capability: 2
Number of Scans (Ns): 1
Response Time: 200 ms
Restore Time: 400 ms

MONITORING PAGE

Home Settings Language Help

Monitoring

Angle: 224.52° Range: 6.612m



Benchmark

Player Model		Datasensing LGS-A10		P-F OBD10M-R2000-4EP		P-F OBD30M-R2000-4EP		SICK TIM-10x		TBD TIM-15x		SICK TIM-320		SICK TIM-350		SICK TIM-360		SICK TIM-781	
Weight	Feature	value	score	value	score	value	score	value	score	value	score	value	score	value	score	value	score	value	score
10	Distance on dark 10%	10	3	3	1	10	3	1,5	-1	3	1	2	0	2	0	8	2	8	2
5	Distance on white 80%-90%	25	2	10	1	30	3	3	-1	10	1	4	0	10	1	10	1	25	2
10	Measurement data available	yes	1	yes	1	yes	1	no	0	no	0	no	0	no	0	no	0	yes	1
5	Systematic error	30	2	25	2	25	2	50	0	40	1	40	1	60	-1	60	-1	60	-1
5	Finest Angle resolution	0,25	2	0,071	3	0,071	3	1	0	1	0	1	0	1	0	0,33	1	0,33	1
2	Dimension WxL	65x65	2	106x106	0	106x106	0	60x59.5	3	60x59.5	3	60x60	3	60x60	3	60x60	3	60x60	3
8	Dimension H	70	3	116.5	0	116.5	0	75.8	3	75.8	3	79	2	79	2	79	2	79	2
5	Min. Response time	40	3	63	2	2	3	70	1	70	1	134	0	134	-1	134	-1	67	2
5	Configurable speeds	3	2	3	2	3	2	1	0	1	0	1	0	1	0	1	0	1	0
10	Simultaneous Zones	3	2	2	1	2	1	2	1	2	1	3	2	3	2	3	2	3	2
10	Banks (Zone Sets)	16	3	4	2	4	2	1	0	1	0	16	3	16	3	16	3	16	3
10	Opening angle	360	3	360	2	360	2	200	0	200	0	270	1	270	1	270	1	270	1
5	Minimum temperature	-10	0	-10	0	-10	0	-10	0	-10	0	-10	0	-25	2	-25	2	-25	2
5	Max. scan frequency	25	1	30	2	30	2	14,5	0	14,5	0	15	0	15	0	15	0	15	0
5	IP protection	IP67	2	IP65	0	IP65	0	IP65	0	IP65	0	IP65	0	IP67	2	IP67	2	IP67	2
Performance		218		130		165		30		65		87		97		122		152	

SCORING SYSTEM

Weight	Feature/Score	yardstick	negative					neutral					positive							
			-1	0	1	2	3	-1	0	1	2	3	-1	0	1	2	3			
5	Distance on dark 10%	m	< 2	2	3	8	> 8													
10	Distance on white 80%-90%	m	< 4	4	10	25	> 25													
10	Measurement data available	mps		No	Yes															
5	Systematic error	mm	> 50	50	40	30	< 30													
5	Finest Angle resolution	°	> 1	1	0,33	0,25	> 0,25													
2	Dimension WxL	mm	> 106x106	106x106	75x75	65x65	< 65x65													
8	Dimension H	mm	> 85	85	80	75	< 75													
5	Min. Response time	ms	134	130	70	63	< 63													
5	Configurable speeds	#		1	2	3	> 3													
10	Simultaneous Zones	#		1	2	3	> 3													
10	Banks (Zone Sets)	#		1	2	4	> 4													
10	Opening angle	°	180	200	270	300	360													
5	Minimum temperature	°C	0	-10	-20	-25	< -25													
5	Max. scan frequency	Hz	<15	15	25	30	> 30													
5	IP protection			IP65	IP66	IP67	IP69K													

LGS-A10
TOP OF RANKING

Function

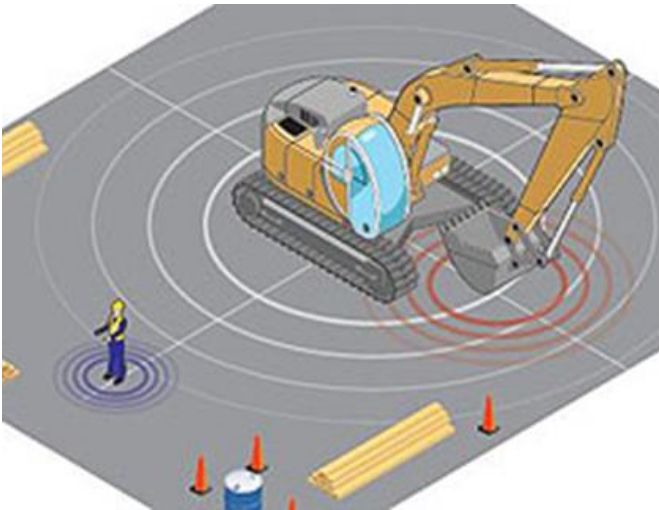

COLLISION AVOIDANCE

- Robot collision avoidance
- Crane collision avoidance
- Earthmoving vehicles collision avoidance
- Agriculture vehicle collision avoidance
- Agriculture vehicle level control
- Intrusion detection



Function

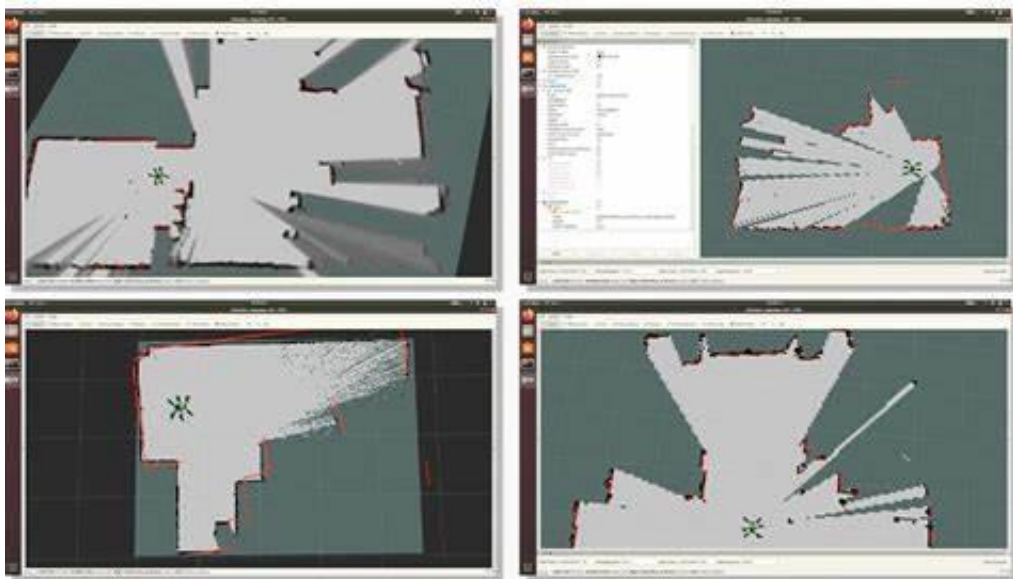

MEASURING, MAPPING and OBJECT DETECTION

- Natural navigation for indoor/outdoor
- Environmental mapping
- Object Measuring
- Object Profiling
- Shape, Area and Volume control

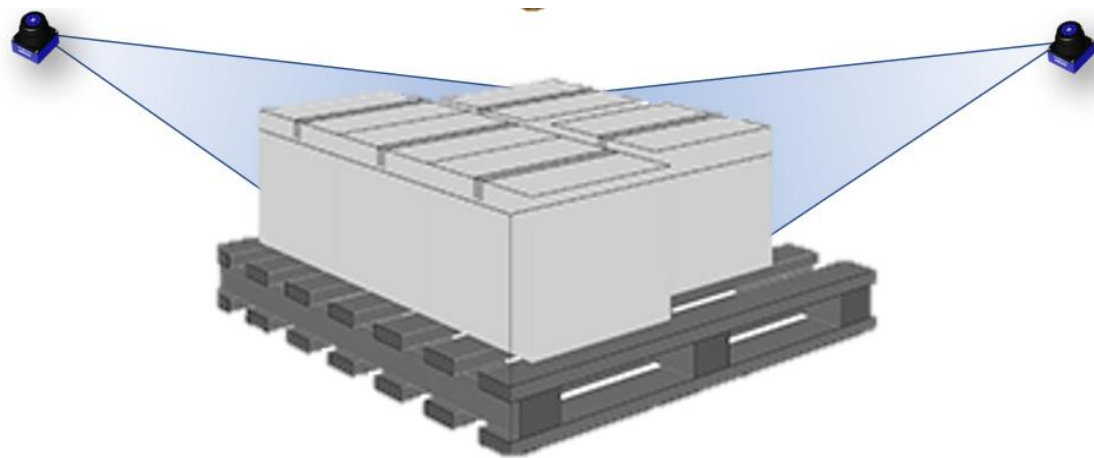
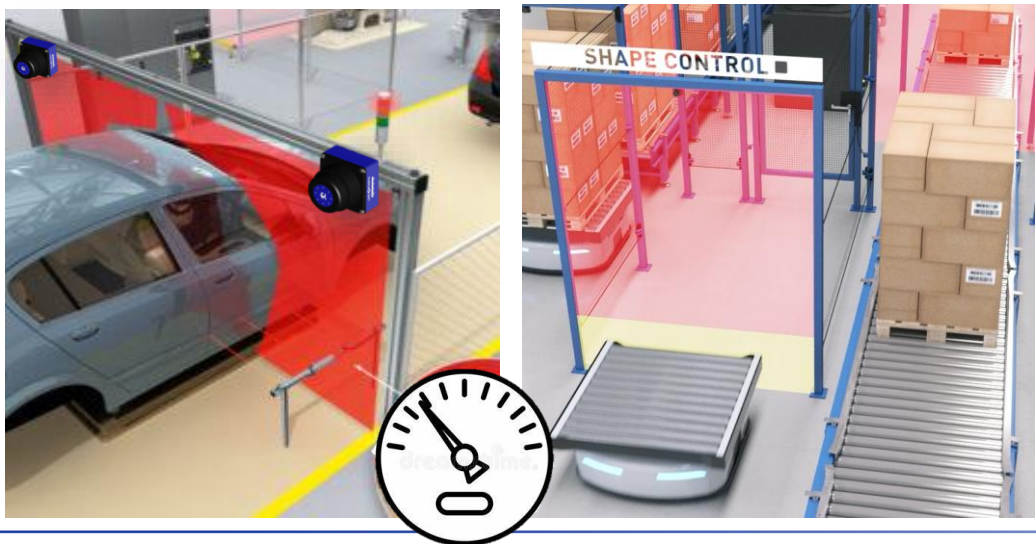

Specific Field Applications



AMR & ROBOTICS

- Shape recognition
- Collision prevention and avoidance
- Collision prevention for postal sanitary shuttle
- Access monitoring
- Natural Navigation (Indoor & Outdoor)
- Other Auxiliary functions



Specific Field Applications



AGV & LOGISTIC

- Load handling
- Lateral monitoring
- Forklift pallet presence
- Rear monitoring and collision avoidance
- Collision prevention
- Dark zone monitoring
- Natural Navigation
- Warehouse pallet presence

Specific Field Applications

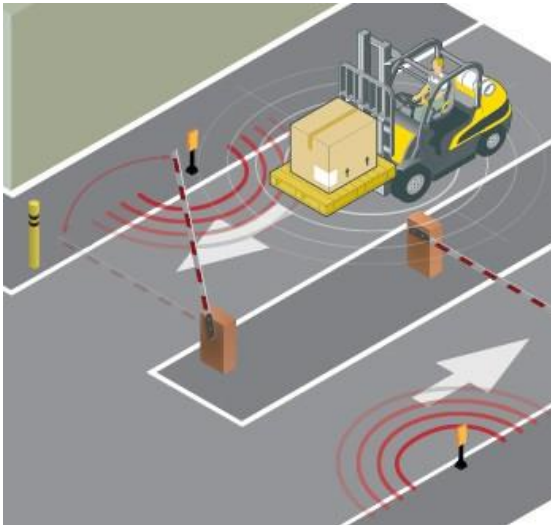
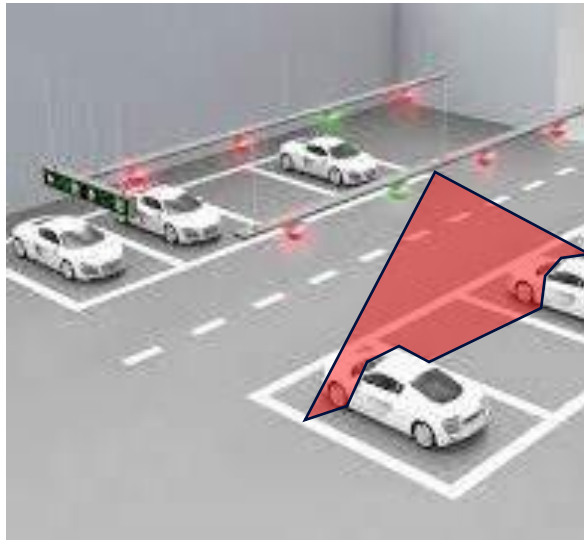

SECURITY, PARK and GATES CONTROLS

- Gate Monitoring
- Parking access control
- Security monitoring
- Object counter



Order information LGS-A10

LGS-A10

Collision avoidance Lidar 360°- 10m

958200002

ACCESSORIES

MAINTENANCE ACCESSORIES		
DESCRIPTION	MODEL	ORDER NO.
Liquid cleaner in spray bottle (1 lt)	SLS-CLEANER	95ASE2990
Cleaning cloth (22 cm x 22 cm), 100 pcs.	SLS-CLOTH	95ASE3000

MAIN CABLES	CS-A1-10-U-03	12 pin female	free wires	3 m	95A252720
	CS-A1-10-U-05			5 m	95A252730
	CS-A1-10-U-10			10 m	95A252740
	CS-A1-10-U-15			15 m	95A252750
	CS-A1-10-U-25			25 m	95A252760
ETHERNET TO HOST CABLES	CAB-ETH-M01 M12-IP67 ETHERNET CAB. (1M)	4 pin male	RJ45	1 m	93A051346
	CAB-ETH-M03 M12-IP67 ETHERNET CAB. (3M)			3 m	93A051347
	CAB-ETH-M05 M12-IP67 ETHERNET CAB. (5M)			5 m	93A051348
	CAB-ETH-M10 M12-IP67 ETHERNET CAB. (10M)			10 m	93A051391





DATASENSING
easing automation challenges

THANK YOU

DATASENSING S.r.l.
Strada Santa Caterina, 235
41122 Modena – Italy

This presentation contains statements that are neither reported financial results nor other historical information. These statements are forward-looking statements. These forward-looking statements rely on a number of assumptions and are subject to a number of risks and uncertainties, many of which are outside the control of DATASENSING S.r.l., that could cause actual results to differ materially from those expressed in or implied by such statements, such as future market conditions, currency fluctuations, the behavior of other market participants and the actions of governmental and state regulators.

© 2022 DATASENSING S.r.l. - All rights reserved. Without limiting the rights under copyright, no part of this documentation may be reproduced, stored in or introduced into a retrieval system, or transmitted in any form or by any means, or for any purpose, without the express written permission of DATASENSING S.r.l. DATASENSING and the DATASENSING logo are trademarks of DATASENSING S.r.l. All other trademarks and brands are property of their respective owners.