



High-Accuracy Position Sensors

K1G Series



Model: K1G

Positionsmessung mit hochgenauen Laser Sensoren

Eine Kombination aus CMOS linear Bildsensor und modernster Lasertechnik garantiert eine extrem schnelle und hochgenaue Objekterkennung und Positionsmessung.

Resolution:
0.1 μm

Measurement
period: 250 μs

- Auflösung 0,1 μm
- Messzyklus 250 μs
- Erfassungsbreite 7 und 15 mm
- Bauhöhe von nur 8 mm (K1G-S07)
- 4-Kanal-Auswertemodul mit integrierten Berechnungsroutinen
- Kantenerkennung bei transparenten Messobjekten



New High-Performance Laser Sensors

Performance and functions far exceed conventional norms, allowing you to make the measurements you want.

A combination of a CMOS linear image sensor and collimated lasers ensures high-accuracy workpiece position measurement.

Model: K1G

See what you previously couldn't. >> 03

Minute variations not visible with conventional sensors can now be reliably detected.



| K1G-S07 |
Measurement Width 7 mm



| K1G-S15 |
Measurement Width 15 mm



| K1G-C04 |
4ch Controller
| K1G-C04M |
MECHATROLINK III Model
| K1G-C04E |
EtherCAT Model

Easily mounts anywhere.

>> 05

Compact dimensions are achieved by slim sensor head design.

Less wasted time.

>> 07

Comes with a full range of functions to help cut job time for design, installation, and maintenance.

In-line inspection of glass edges

Up until now glass edges and surfaces were checked offline by operators for defects such as chips. The Model K1G, however, makes high-speed in-line measurements with a high degree of accuracy. This means that fast, highly accurate glass measurements can now be made regardless of how the edge surface is processed.

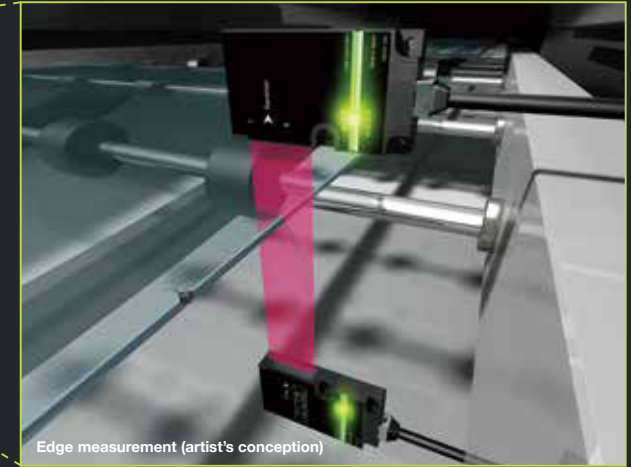
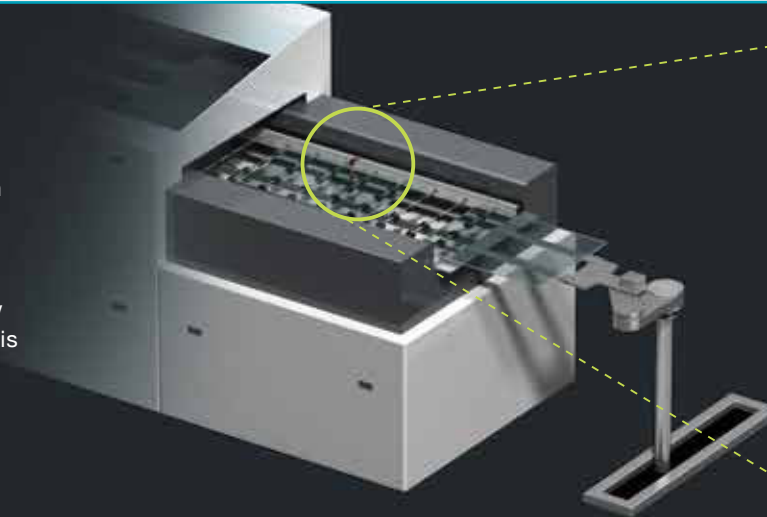

Edge measurement (artist's conception)

0.1 μm resolution —the highest level in its class!

Azbil's unique FDN algorithm, which utilizes Fresnel diffraction phenomena and sophisticated high resolution technologies, has achieved detection accuracy down to 0.1 μm with repeatability accuracy to 1 μm.

- Fresnel diffraction: Light is diffracted by the edges of thin objects such as knives and films. The intensity distribution of diffracted light at the receiver depends on the working distance between the target object and the receiver.
- FDN is Azbil's Fresnel diffraction -based sub-pixel processing algorithm.

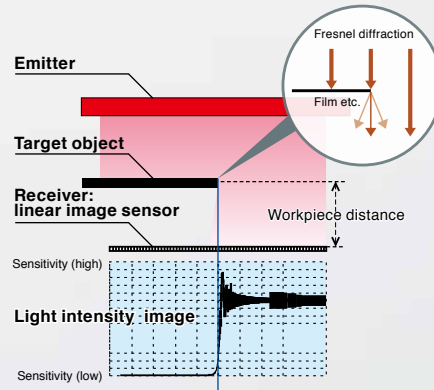

250 μs measurement period, the fastest in its class.

Dual-engine architecture allows the integrated FDN algorithm to process huge amounts of data at high speed. By means of multitasking, processing speed is accelerated to approximately four times that of conventional models.

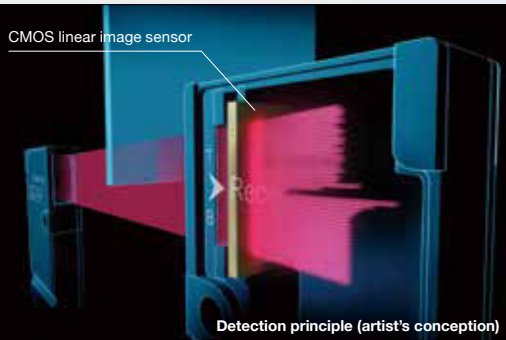

Detection principle (artist's conception)

Detection principle works well for transparent object detection.

We developed a special lens to achieve almost perfectly parallel optical light, and then added a CMOS linear sensor as the light-sensitive element to enable visual perception of workpiece position.

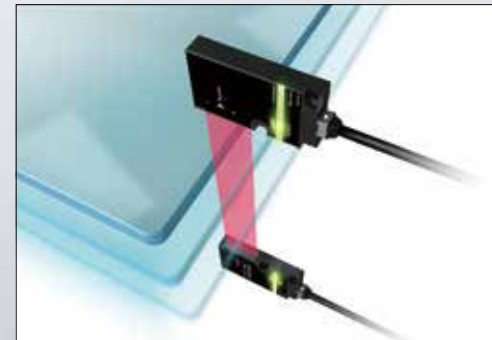

Workpiece distance setting

A built-in function adjusts for minute offsets caused by fluctuations in workpiece position, resulting in highly advanced, more accurate detection.

Easily mounts anywhere.

8 mm thin!

K1G-S07

Have you encountered “doesn’t fit” or
“can’t measure” problems due to sensor size?
Model K1G-S designers made ultra-slimness
a high priority.





Wafer alignment in IC manufacturing

A small sensor head allows a small alignment unit, helping to reduce the overall equipment footprint.

Facilitates miniaturization

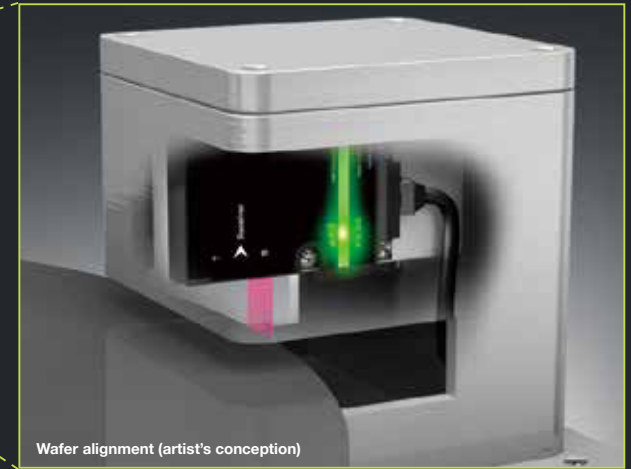
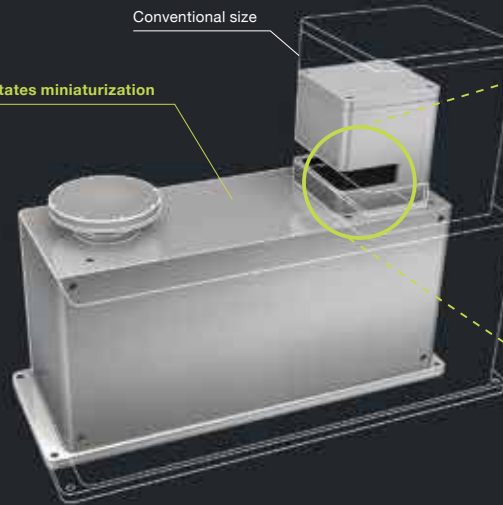

Wafer alignment (artist's conception)

Ultra-thin sensor head

Meticulous efforts have produced an ultra-thin head in all its dimensions. Two sensor models, having detection ranges of 7 mm and 15 mm, are available and are ideal for a wide diversity of applications.

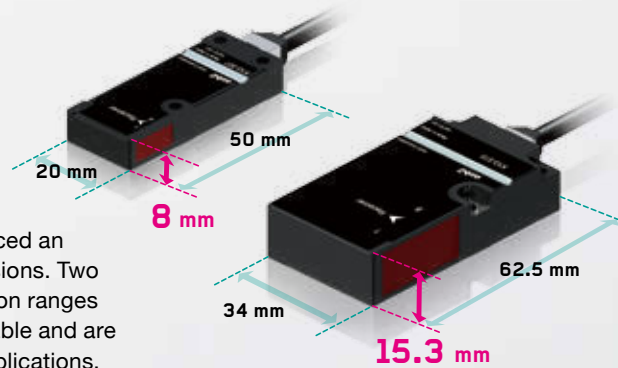

Panel-mount multi-channel controller

A single controller can connect to as many as four sensor heads. Two types of sensor head can be used together.



Various types of display

Sensor cable relay connectors

With easy installation and maintenance in mind, we designed panel-mount connectors.

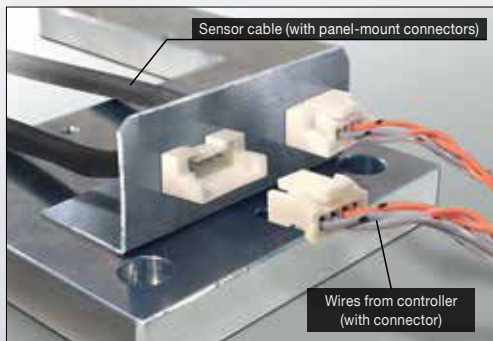

Sensor cable (with panel-mount connectors)

Wires from controller (with connector)

Up to 25 meter cable extension

The maximum cable extension distance is now dramatically improved compared with conventional products. Installation points are easy to find when there are no worries about cable length.

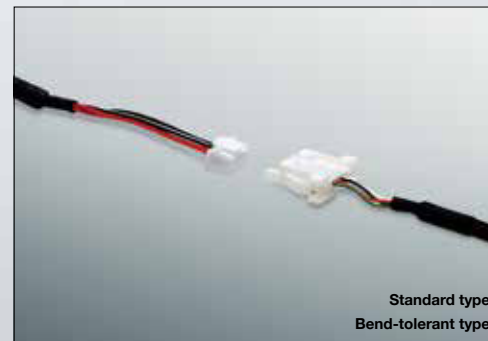

Standard type
Bend-tolerant type

Less wasted time.

The Model K1G is equipped with a host of functions to fully streamline your work time before and after measurement.

Built-in test mode

Model K1G controllers include a "test mode" to allow you to freely switch between analog and digital output, so that connections can be checked before the start of equipment operation.

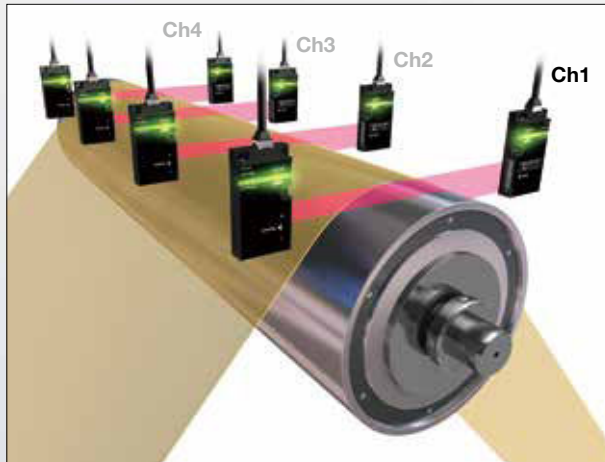
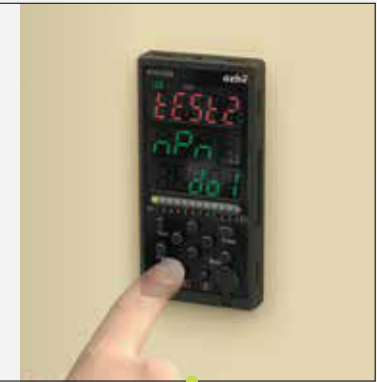

Built-in multi-calculation functions

Multi-channel controllers help calculate data between channels. This cuts the time needed to write programs for host computing equipment and enables easy measurement of thicknesses and widths.

Output of processed results

AO1: Ch2 - Ch1, AO2: Ch3 - Ch1, AO3: Ch4 - Ch1

$$AO4: \frac{(Ch2 + Ch3 + Ch4)}{3} - Ch1$$



Sensor selection and equipment design

Various built-in measurement modes

One sensor can measure up to two positions at the same time. This means that a single device can handle different applications including workpiece edge position, edge dimensions, hole diameter, and many others, eliminating the trouble of selecting devices.

Blocked light width measurement

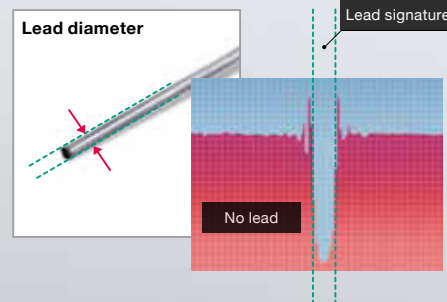

Entering light width measurement

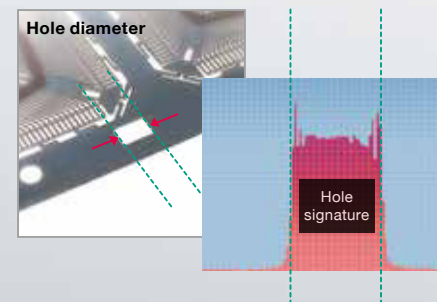

Edge position measurement

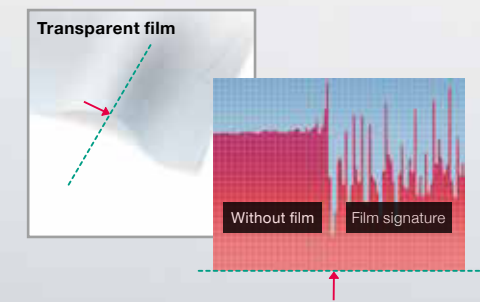



Enhanced light-axis adjustment function

The light-axis alignment function is an advance over that of conventional models. A light reception indicator mounted on the sensor head significantly cuts the time needed for alignment.

Dust detection function

If dust on the receiver or ambient light interference is detected, output notifies the user before the problem affects measurement, allowing timely preventive maintenance. The function also helps to cut time spent on unneeded maintenance.



Sensor installation

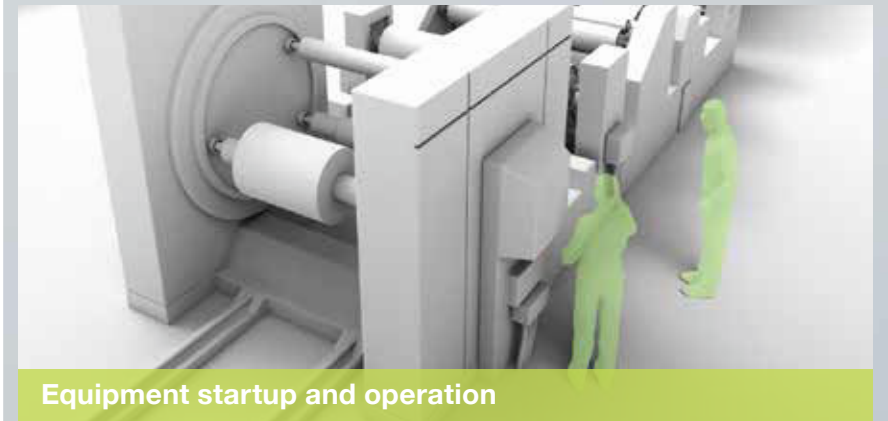

Equipment startup and operation



Special setup tool collects measured data

Measurement data can be acquired every 250 μ s, and measurement status can be checked without connecting to a host device, allowing smooth equipment startup.

Incoming light distribution when event occurred

Abnormal state when event occurred

Before event occurrence

After event occurrence

Measurement data before and after event occurrence

Time	Value	Time	Value
00:00:00	0.000	00:00:00	0.000
00:00:01	0.000	00:00:01	0.000
00:00:02	0.000	00:00:02	0.000
00:00:03	0.000	00:00:03	0.000
00:00:04	0.000	00:00:04	0.000
00:00:05	0.000	00:00:05	0.000
00:00:06	0.000	00:00:06	0.000
00:00:07	0.000	00:00:07	0.000
00:00:08	0.000	00:00:08	0.000
00:00:09	0.000	00:00:09	0.000
00:00:10	0.000	00:00:10	0.000
00:00:11	0.000	00:00:11	0.000
00:00:12	0.000	00:00:12	0.000
00:00:13	0.000	00:00:13	0.000
00:00:14	0.000	00:00:14	0.000
00:00:15	0.000	00:00:15	0.000
00:00:16	0.000	00:00:16	0.000
00:00:17	0.000	00:00:17	0.000
00:00:18	0.000	00:00:18	0.000
00:00:19	0.000	00:00:19	0.000
00:00:20	0.000	00:00:20	0.000
00:00:21	0.000	00:00:21	0.000
00:00:22	0.000	00:00:22	0.000
00:00:23	0.000	00:00:23	0.000
00:00:24	0.000	00:00:24	0.000
00:00:25	0.000	00:00:25	0.000
00:00:26	0.000	00:00:26	0.000
00:00:27	0.000	00:00:27	0.000
00:00:28	0.000	00:00:28	0.000
00:00:29	0.000	00:00:29	0.000
00:00:30	0.000	00:00:30	0.000
00:00:31	0.000	00:00:31	0.000
00:00:32	0.000	00:00:32	0.000

Sophisticated built-in event log function

The controller can save measurement data from 32 points before and after the occurrence of an event, as well as the incoming light distribution when the event occurred. This allows investigation of the cause of an event while still in the field and also reduces troubleshooting time.

Typical applications

■ Wafer alignment

Highly transparent glass or gallium arsenic wafers can be reliably measured with a high degree of accuracy. 450 mm wafer notches can also be measured with good reliability at a measuring cycle of 250 μ s.

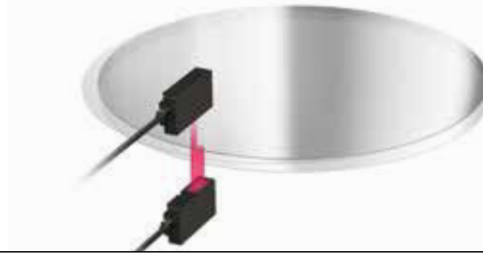

■ Film meander measurement

By using both of the sensor head channels, the controller's calculation function can simultaneously measure film meander and film width.

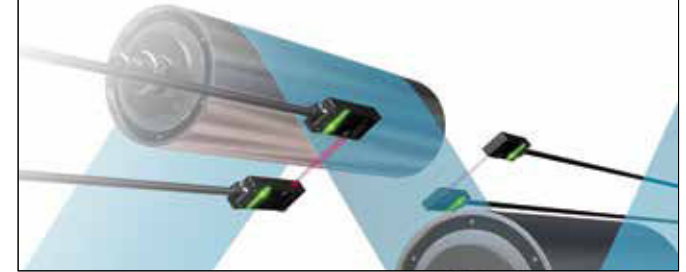

■ Film sheet thickness measurement

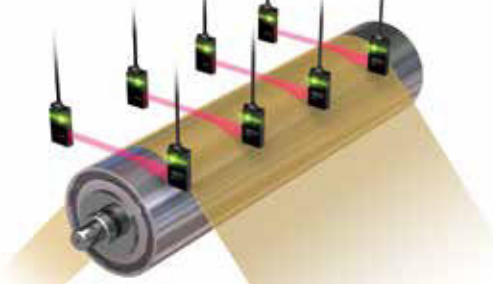

A controller can connect to as many as four sensor channels to provide simultaneous measurement of multiple points, delivering even more accurate measurements.

■ Measurement of gap between rollers

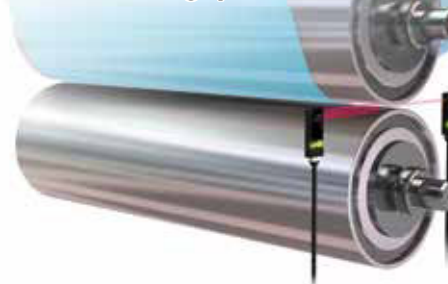

A combination of collimated lasers and image sensor gives measurements of workpiece edge position with a high degree of accuracy.

■ Detection of intermixed electronic components

At a resolution of 0.1 μ m, measurements can be made with a high degree of accuracy. A small sensor head means that in-line measurements can be made in very restricted spaces.

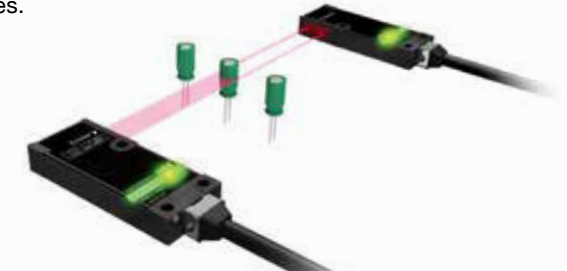

■ Measuring the inner diameter of pressed material

The 0.1 μ m resolution allows for highly accurate measurement. A built-in function for detecting foreign matter on the sensor head is helpful for preventive maintenance.

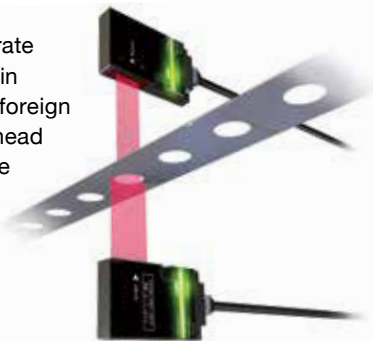

■ XY θ measurement of glass substrates

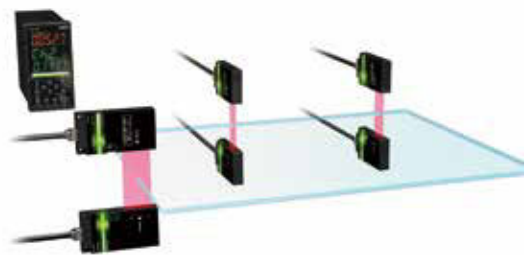

By connecting sensors on three channels to a multi-channel controller, the displacement (X, Y, θ) of a glass substrate can be calculated without programming.

■ Detection of glass substrate irregularities

The response speed of 250 μ s ensures detection of any irregularities on glass substrates while they are being transported. The event log function allows quick analysis if any problem occurs.



Various interfaces



There's no need to worry about how to connect to a host device.

Simply select the interface that is best for your system environment.

〈Supported interfaces〉

MECHATROLINK-III / EtherCAT / Modbus RTU / Analog output (voltage/current) / DI/O (NPN/PNP)

Stepping up to a new level of measurement

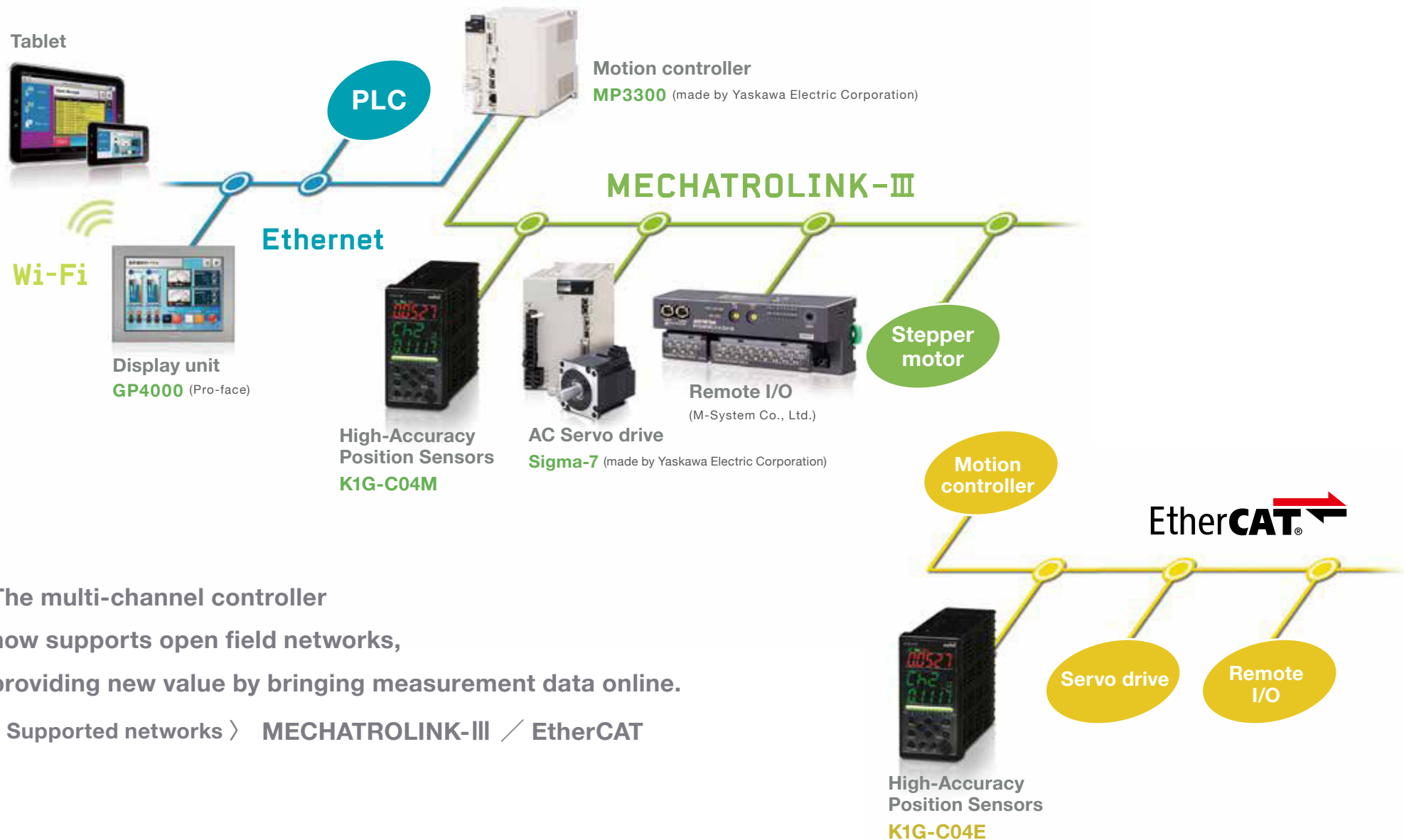

The multi-channel controller now supports open field networks, providing new value by bringing measurement data online.

〈 Supported networks 〉 MECHATROLINK-III / EtherCAT

POINT 1 Small footprint and less wiring

High-speed communications to a maximum of 100 Mbps and high-reliability protocols allow the transfer of measurement data over communication networks. Since input and output require only two wires, the number of wires and space for installation can be greatly reduced.

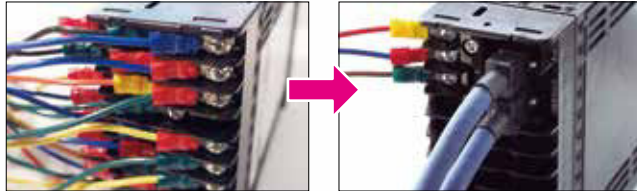

Conventional wiring

Reduced wiring



POINT 3 Node synchronization

To guarantee data synchronization, MECHATROLINK-III/EtherCAT allows easy extraction of synchronized data from all devices on the network. This, for example, allows checking of operations after tooling changes and efficient pinpointing of any trouble that might occur.

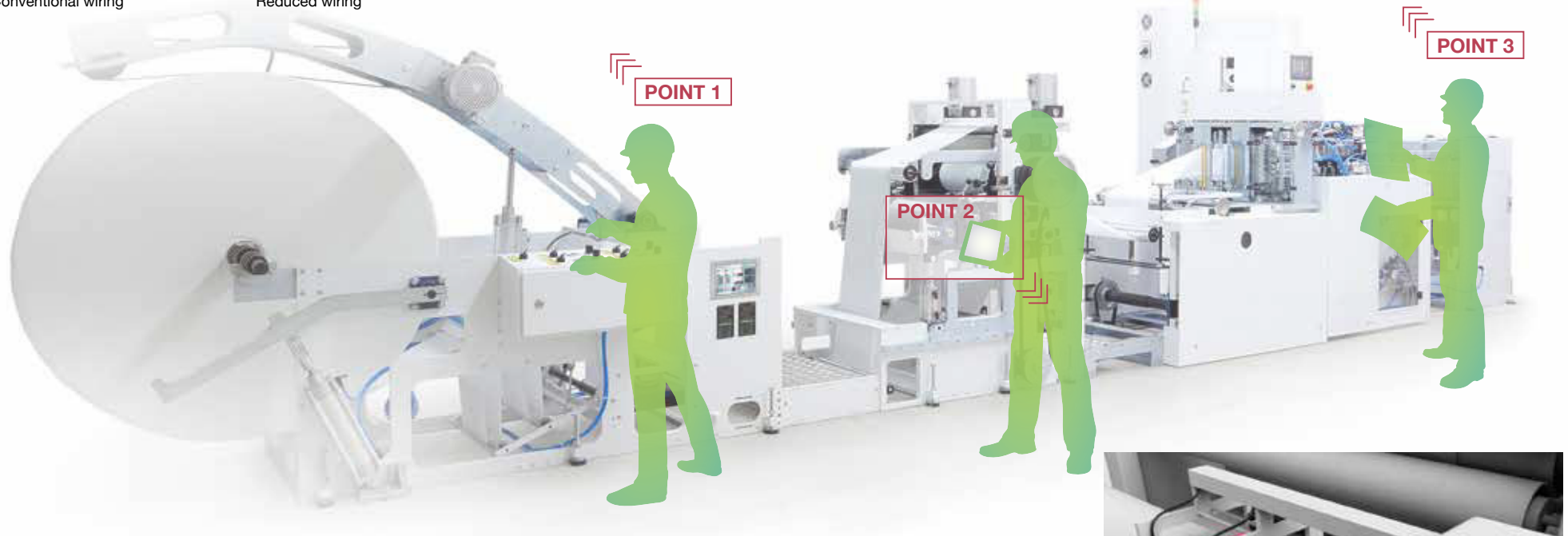

POINT 2 User-friendly setup and adjustment with HMI



Using the Pro-face GP4000 series allows the setting and checking of all parameters used by the K1G series. The Pro-face Remote HMI, on the other hand, allows setting and checking of parameters using a Wi-Fi-equipped tablet.

Supported devices: K1G-C04 / K1G-C04G / K1G-C04M / K1G-C04MG



Specifications

Sensor heads

Catalog listing	K1G-S07	K1G-S15
Shape		
Compatible controllers	K1G-C04 □	
Detection type	Thru-scan (Emitter, Receiver set)	
Sensing distance	10 to 500 mm	10 to 1000 mm
Sensing width	7 mm	15 mm
Light source	Red semiconductor laser (light emission peak 650 nm), JIS Class 1	
Standard target	Opaque knife edge	
Repeatability	±1 μm or less *1	
Moving accuracy	20 μm or less when moved 0.5 mm *2	
Temperature characteristics of sensor	0.1%F.S./°C	
Indicator lamp	Operation indicator: yellow LED	
Operating temperature	0 to 50°C	
Storage temperature	-20 to 70 °C (without freezing)	
Operating humidity	30 to 85 % RH (without condensation)	
Vibration resistance	9.8 m/s ² (10 to 55 Hz), 2 h each in X, Y and Z directions	
Protective structure	IP40 (IEC standard)	
Connection type	220 mm connector cable	

*1. Accuracy specifications are for 23±2 °C under the conditions below.



Catalog listing	SD	WD	Object position	Averaged trials
K1G-S07	20 mm	10 mm	Center of measurement beam	64
K1G-S15	100 mm	50 mm	1 mm position from center of measurement beam	

*2. Accuracy specifications are for 23±2 °C under the conditions below.

Catalog listing	SD	WD	Object position
K1G-S07	20 mm	10 mm	Center of measurement beam
K1G-S15	100 mm	50 mm	1 mm position from center of measurement beam

SD: Sensing distance WD: Object-receiver distance

Junction cables

Appearance	Catalog listing (cable length in parentheses)	Type	Description
	K1G-L □ □ *3	K1G-L01 (1 m)	Standard junction cables (2)
		K1G-L03 (3 m)	
		K1G-L05 (5 m)	
		K1G-L10 (10 m)	
	K1G-R □ □ *3	K1G-R01 (1 m)	Bend-tolerant junction cable (1)
		K1G-R03 (3 m)	

*3: □ □ stands for cable length. *4: *S" is appended to shielded cable model numbers. Ex.: **K1G-L01S**

Sensor head external dimensions (unit: mm)

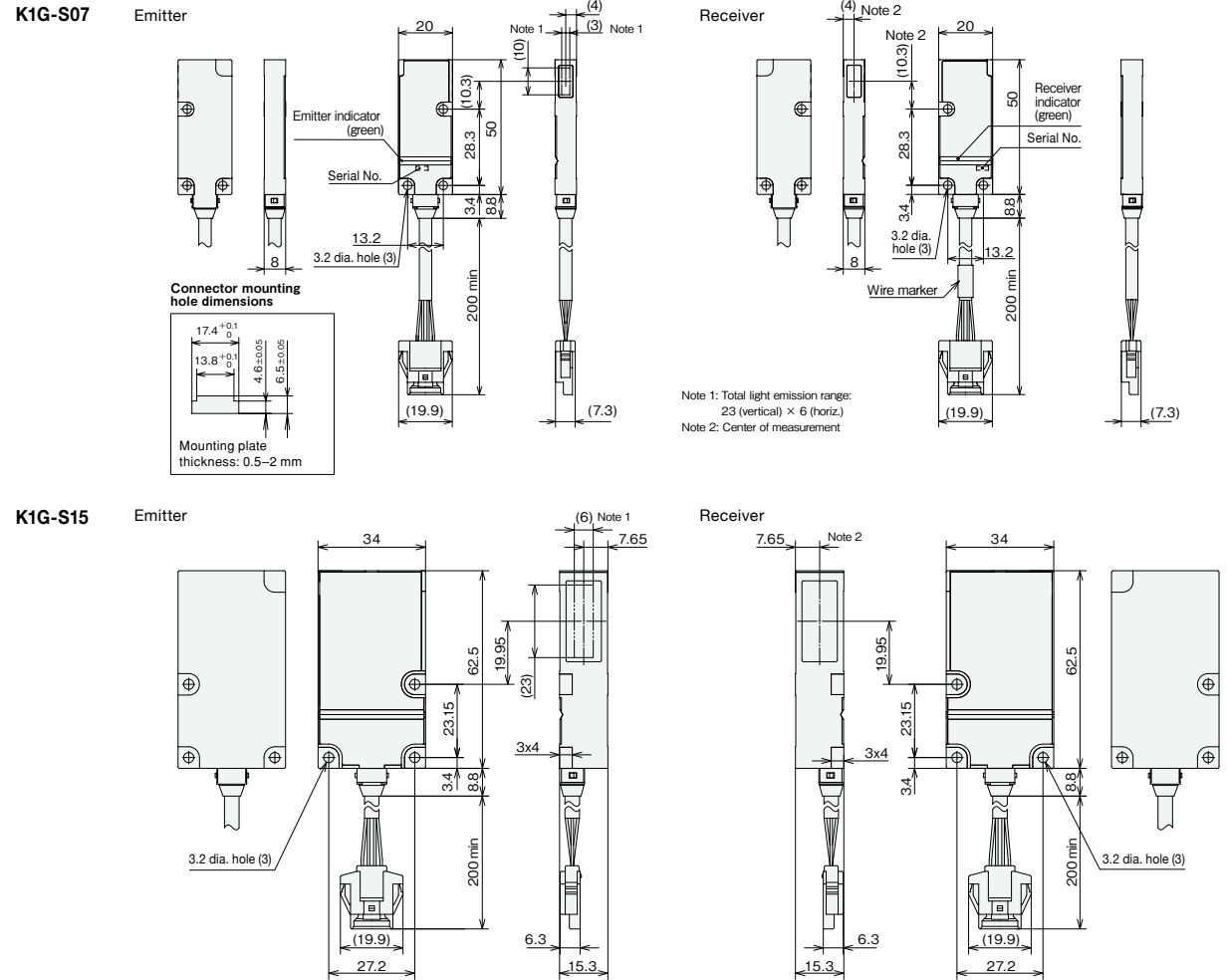

Junction cable external dimensions (unit: mm)

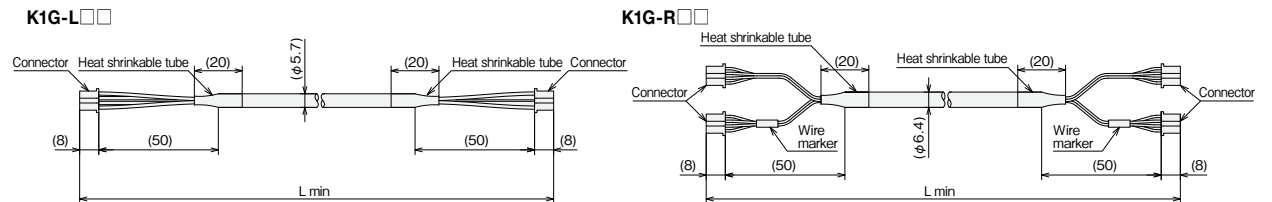

Controllers

Catalog listing		K1G-C04 K1G-C04G	K1G-C04M K1G-C04MG	K1G-C04E K1G-C04EG
Shape				
Compatible sensor		K1G-S □□		
Max. number of connected sensors		4		
Reading	Min. display unit	0.1 μm		
	Display range	With K1G-S07	0 to 7 mm or -3.5 to +3.5 mm can be selected	
		With K1G-S15	0 to 15mm or -7.5 to +7.5 mm can be selected	
Measurement cycle (Output update cycle)		250 μs / 500 μs / 1 ms (switchover) *1 *3		
Analog output		4 outputs: 4 -20 mA or 1 -5 V (all outputs are switched over at once)	—	—
Digital output		8 outputs: NPN or PNP transistor (all outputs are switched over at once) *2	—	—
Digital input		4 inputs: non-voltage contacts and NPN or PNP open collector (all points are switched over at once)	—	—
Communications		RS -485 (Modbus RTU)	MECHATROLINK-III	EtherCAT
Supply power		DC12 to 24V ±10%		
Operating temperature		0 to 50 °C (0 to 35 °C if gang-mounted)		
Storage temperature		-20 to 70 °C (without freezing)		
Operating humidity		30 to 85 % RH (without condensation)		
Vibration resistance		2 m/s ² (10 to 60 Hz), 2 h each in X, Y and Z directions		
Protection circuit		Power reverse connection protection		

* 1: The measurement cycles that can be selected vary depending on the cable length.
Refer to the table below to select the right cable length for the desired measurement cycle.

Catalog listing	Measurement interval		
	250 μs	500 μs	1 ms
K1G-L □□	5 m or less	20 m or less	25 m or less
K1G-R □□	3 m or less	5 m or less	10 m or less

* 2: Output is not open collector.



* 3: For CE-marked and KC-marked models (K1G-C04_G), a measurement cycle of 250 μs cannot be selected.

Be sure to observe the wiring and setup details described in the installation procedure below. (Otherwise, the device will not satisfy the required level of compliance with the EMC Directive.)





Note: For products with CE or KC marking, contact the closest Azbil branch or sales office.

* Two SZ-E02 ferrite cores are included with the K1G-C04E(G).

Options

Appearance	Catalog listing	Description
	81441421-001	Front protective cover for controllers
	SZ-A03	Sensor head cable (spares can be purchased separately)
	SZ-E01	Ferrite cores for sensor heads (2 cores are included)
	SZ-E02	Ferrite cores controller (1 core is included)

Special accessories for K1G

Appearance	Catalog listing	Description
	SZ-D01	Settings display unit (5.7 inch)
		Special stand
		Loader cable This cable is necessary for connecting the K1G to the settings display unit.
	81442773-001	DC jack cable The cable is necessary for connecting the AC adapter with the setting display.
	81446957-001	AC adapter (AC 100 -240 V / DC 24 V)

Controller dimensions (unit: mm)

K1G-C04

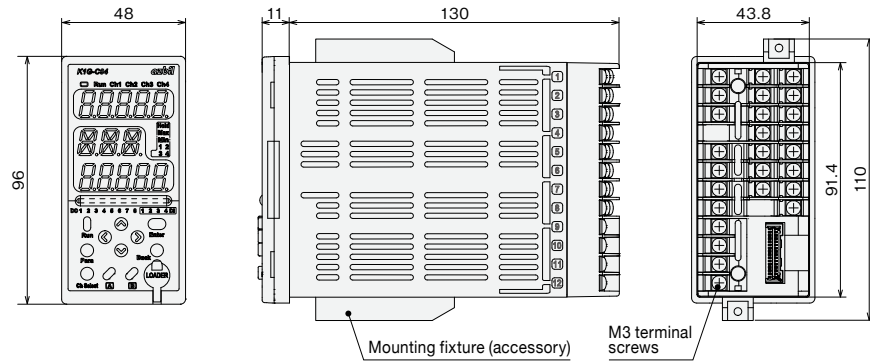

K1G-C04 Terminal arrangement

Terminal No.	A	C	F
1	Power, 24 Vdc	RS-485 DA	AO1 +
2	Power, 0V	RS-485 DB	AO1 -
3	FG	RS-485 SG	AO2 +
4	DO1	DI1	AO2 -
5	DO2	DI2	AO3 +
6	DO3	DI3	AO3 -
7	DO4	DI4	AO4 +
8	DO5	—	AO4 -
9	DO6	Sensor head connection	
10	DO7		
11	DO8		
12	—		

K1G-C04E (EtherCAT communication model)

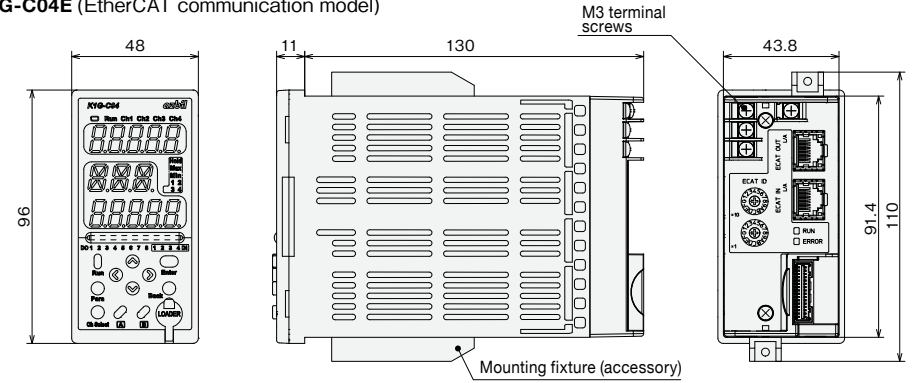

K1G-C04E Terminal arrangement

Power		EtherCAT	
A1	Power +	C1	EtherCAT FG
A2	Power -		
A3	FG		

K1G-C04M (MECHATROLINK-III communication model)

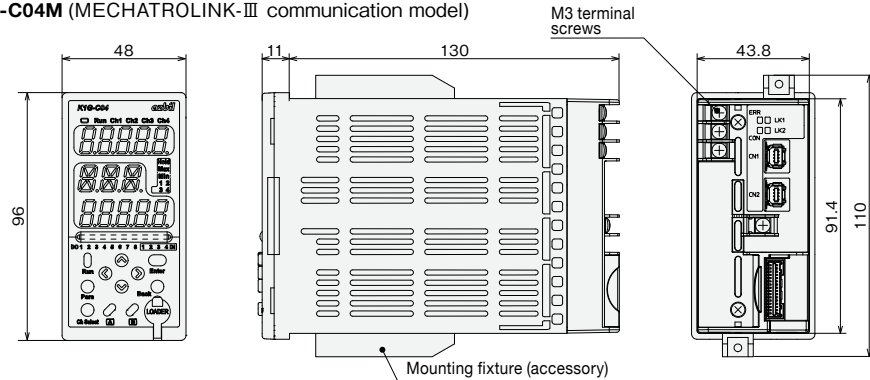

K1G-C04M Terminal arrangement

Power		MECHATROLINK-III	
A1	Power +	CN1	Connector 1
A2	Power -	CN2	Connector 2
A3	FG	C7	FG

Sensor head cable external dimensions (unit: mm)

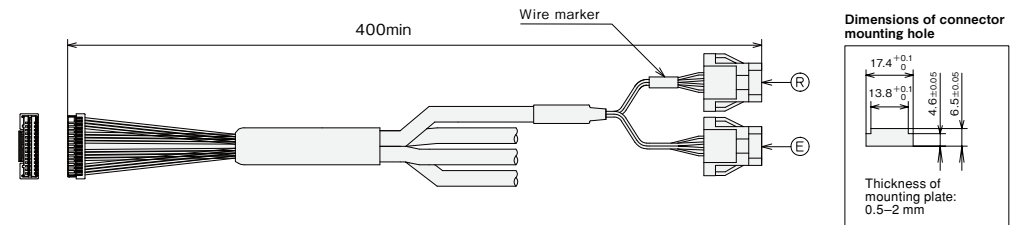

R and E in the figure indicate which sensor head is connected.
 R: connected to the receiver by the junction cable (with wire marker)
 E: connected to the emitter by the junction cable

Wiring/connecting a CE- or KC-marked product (K1G-C04_G)

Attaching ferrite cores

● For K1G-C04G and K1G-C04MG

- Attach the SZ-E02 ferrite core to the power wires (not included with the product) to the controller making 2 turns (1 loop). In this case, the both power wires (V+ and V-) must be looped.

● For K1G-C04EG

- Attach the SZ-E02 ferrite core to the power wires (not included with the product) to the controller making 3 turns (2 loop). In this case, the both power wires (V+ and V-) must be looped.
- Attach the SZ-E02 ferrite core to the sensor head cable, making 1 pass through the core.

● For all models

- Attach the SZ-E01 ferrite cores to the cables of the sensor heads (emitter and receiver), making 2 turns (2 passes through the core).

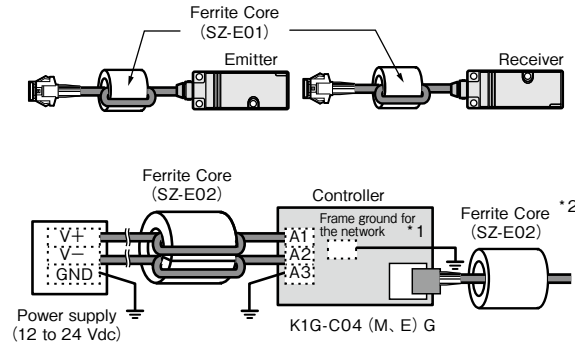

*1 K1G-C04MG: terminal C7. K1G-C04EG: terminal C1

*2 K1G-C04EG only

Wiring and connecting K1G-C04E (EtherCAT)

Attaching ferrite cores

- Attach the ferrite cores (included) to the power wires of the controller (not included).
- Attach the ferrite cores to the sensor head cables.

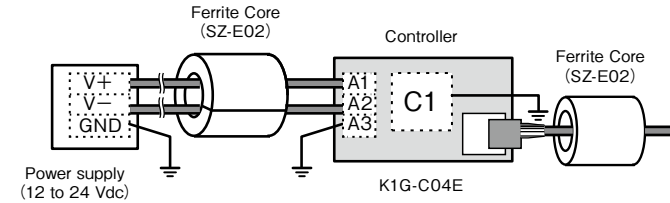

Connecting shielded junction cables

- Connect the junction cable to the connectors at the controller end and the sensor head end, and cover the cable including both connectors with an electromagnetically shielded conduit or the like.
- Ground the junction cable shield wire.

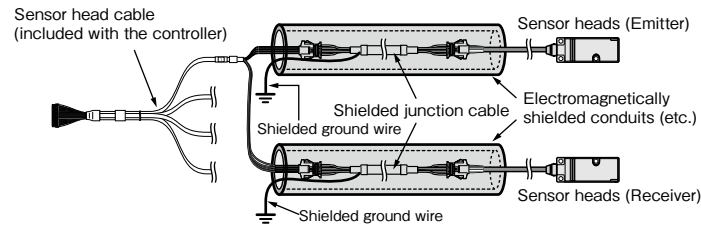

Connecting shielded junction cables

- Use a shielded junction cable (K1G-L_S or K1G-R_S).
- Ground the shielded wire of the junction cable.

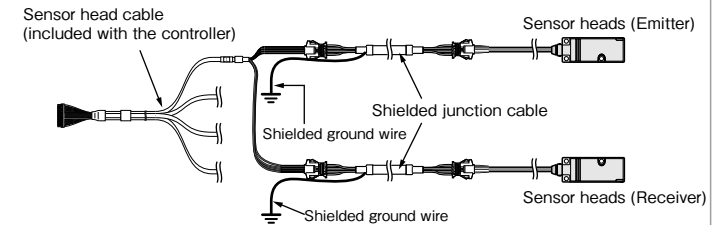

Connecting EtherCAT communication cables (for K1G-C04EG only)

- Use a noise-resistant double-shielded cable (not included with the product) for communication.
- Remove the jacket at both ends and ground the shield using a cable clamp (not included).

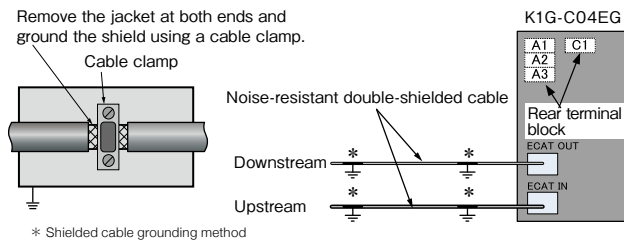

* Shielded cable grounding method

Connecting EtherCAT communication cables

- Use a double-shielded cable (not included) for communication.
- Remove the jacket at both ends and ground the shield using a cable clamp (not included).

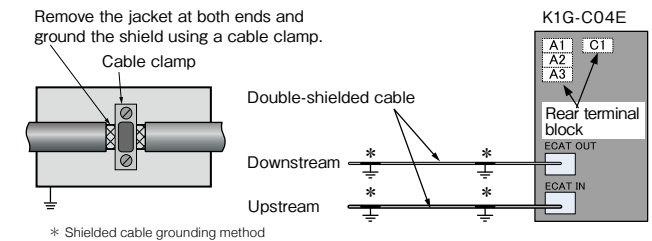

* Shielded cable grounding method

Appendix

Mounting the sensor head reference information

This section provides information on various parts that may be necessary for installation and maintenance. Please select and use the parts that are appropriate for your purposes and usage environment. Consider using a simple adjustable unit for positioning in order to easily fine-tune sensor attachment locations or modify the setup.

Mounting bracket for sensor head

Refer to the figure on the right when constructing the bracket

K1G-S07

Hardware combination example

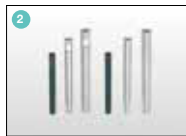
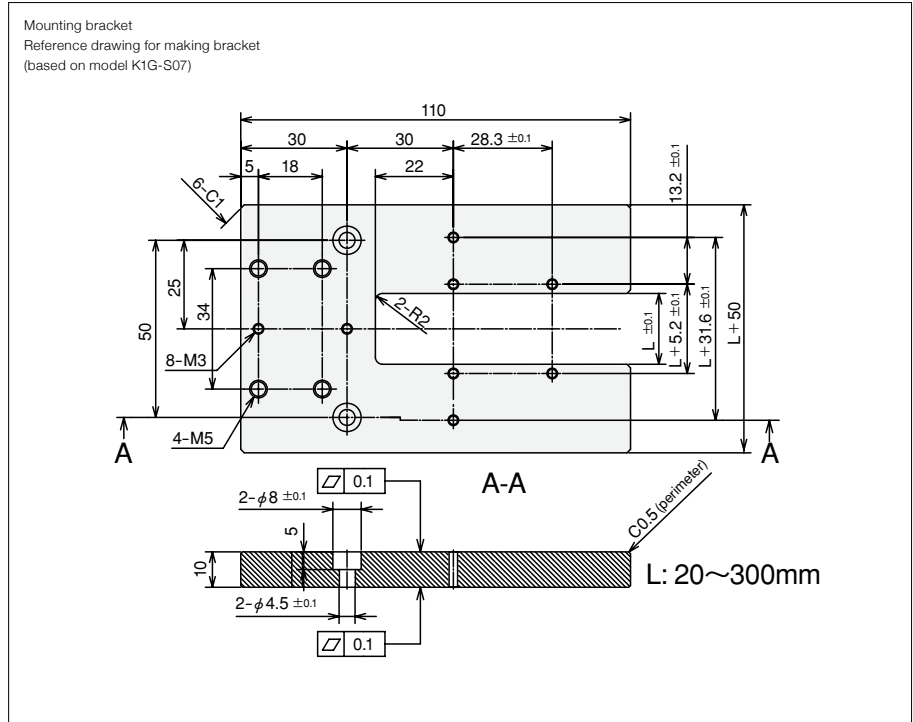
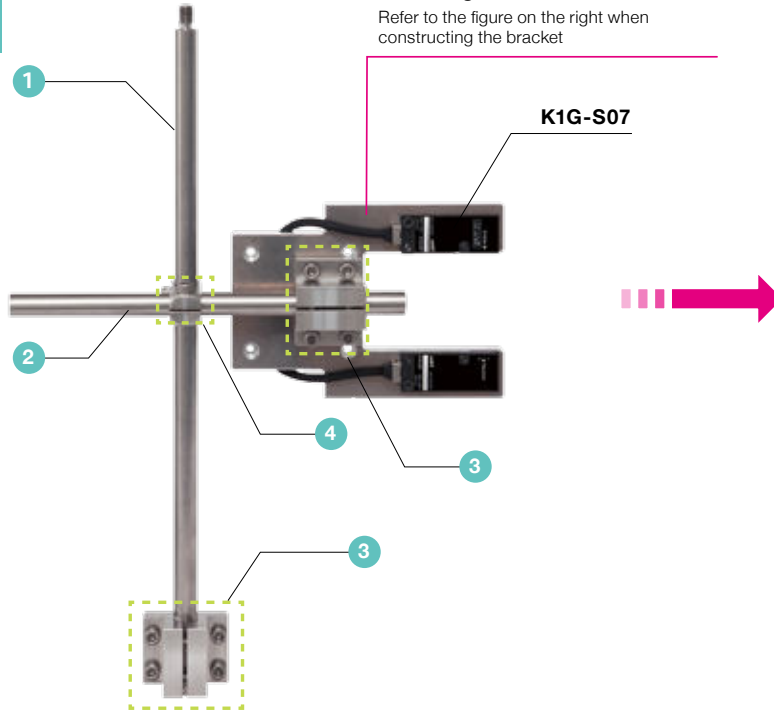

Example of a simple adjustable unit



Model: K1G

Sensors

K1G-S07 | Measurement Width 7mm **K1G-S15** | Measurement Width 15mm

Controllers

K1G-C04 | 4ch Controller **K1G-C04M** | MECHATROLINK III Model **K1G-C04E** | EtherCAT Model

Please read "Terms and Conditions" from the following URL before ordering and use.

<http://www.azbil.com/products/factory/order.html>

MECHATROLINK is a trademark of the MECHATROLINK Members Association.

Wi-Fi is a trademark of Wi-Fi Alliance.

Other product names, model numbers and company names may be trademarks of the respective company.

[Notice] Specifications are subject to change without notice. No part of this publication may be reproduced or duplicated without the prior written permission of Azbil Corporation.

Azbil Corporation

Advanced Automation Company

Yamatake Corporation changed its name to Azbil Corporation on April 1, 2012.

1-12-2 Kawana, Fujisawa
Kanagawa 251-8522 Japan

URL: <http://www.azbil.com>

1st Edition: Issued in May. 2014-SK
6th Edition: Issued in Sep. 2017-SK